

Slide Carburettor Type 54-2

FIG No.	DESCRIPTION	BING No.
1	MAIN JET	44-051-XXX
2	ATOMIZER	51-550-XXX
3	NEEDLE JET	45-120-XXX
4	JET NEEDLE	46-360-XXX
5	IDLE JET	44-353-XXXX
6	AIR SCREW	50-039
7	O'RING	65-704
8	AIR SLIDE	22-XXX
9	JET STOCK	45-435
10	SCREEN	57-706
11	CLIP	57-251
12	RETAINER	26-512
13	IDLE SPEED	50-072
14	SPRING	60-322
15	SLIDE SPRING	60-XXX
16	COVER	20-672
17	O'RING	65-745
19	ADJUSTER	50-050
20	NUT	42-605
21	BOOT	65-851
22	CABLE GUIDE	55-125, 135
23	NUT	42-702
24	FLOAT - stock	35-300
	FLOAT - Ind	35-IND
25	PIVOT PIN	52-058
26	FLOAT NEEDLE	47-968
27	LOCK SPRING	61-420
28	FLOAT BOWL	30-XXX
29	FLOAT BOWL	30-922/150
30	BOWL GASKET	65-584
31	BOWL CLIP	61-479
32	CLAMP	59-130
33	BOLT	40-636
34	NUT	42-611
35	TICKLER	48-830
36	SPRING	60-062
37	PIN	29-020
38	CHOKE	24-055
39	SPRING	60-195
40	PISTON	22-935
41	BUSHING	50-672
42	SPRING	60-180
43	INSERT	50-720
44	PISTON	22-956
45	SPRING	60-179
46	INSERT	51-721
47	BOOT	80-725
48	START LEVER	58-986
49	SCREW	40-566
50	WASHER	61-681
51	NUT	42-502
52	VENT TUBE	80-711
53	BUSHING	65-636
54	SCREW	40-518
55		

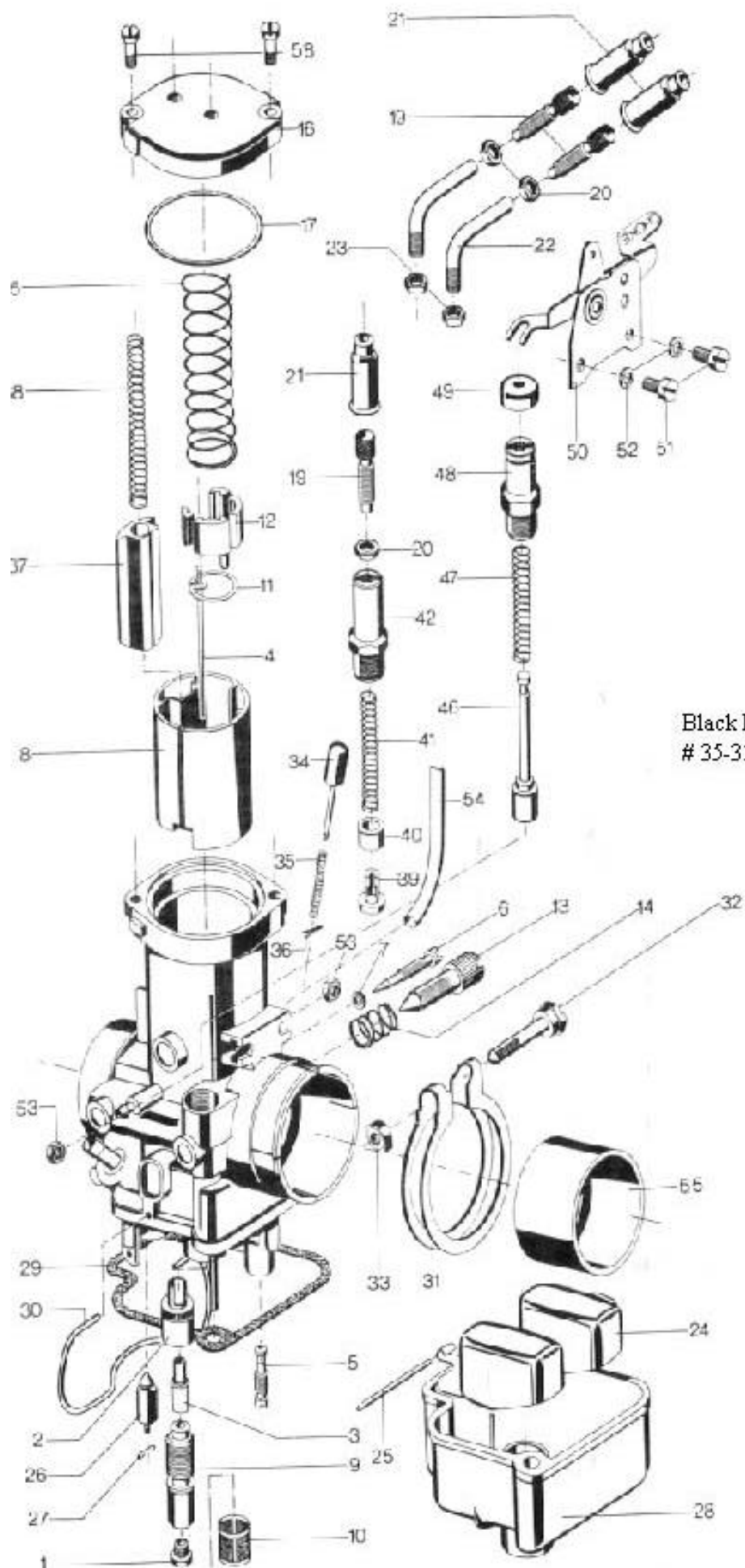

Black Float
35-310

Float Needle Seat 51-536-XX