

# **Pocket Guide**

# **SDH**



**Wandel & Goltermann**  
Communications Test Solutions



## **The sun is made of copper ...**

Anyone making a statement like that these days would likely be considered as quite mad, yet with these words, spoken back in 1861, Johann Philipp Reis began something that has completely changed the world. This meaningless message, just spoken by Reis into his new invention, was clearly heard by the receiver. The telephone was born. Despite this, the first usable telephone (A.G. Bell, 1876: Patent for electrical and magnetic transmission of sounds) was thought of as little more than a toy.

Today, it would be difficult for us to imagine life without the telephone. World-wide, there are some 750 million telephone connections in use and the number of Internet users has exploded in the last few years. By the year 2000, according to a forecast from Nortel, there will be almost 475 million Internet users and the number of services provided will also grow rapidly.

Right from the start, network providers have been faced with coping with a steadily increasing number of users and thus of telephone traffic. This led to the development of various methods and technologies, designed on the one hand to meet the market needs and on the other hand to be as economical as possible. In the field of communications engineering, this resulted in the introduction of frequency division multiplex (FDM) systems which enabled several telephone connections to be transmitted over a single cable. The idea was to modulate each telephone channel with a different carrier frequency to shift the signals into different frequency ranges.

With the advent of semiconductor circuits and the ever-increasing demand for telephone capacity, a new type of transmission method called pulse code modulation (PCM) made an appearance in the 1960s. PCM allows multiple use of a single line by means of digital time-domain multiplexing. The analog telephone signal is sampled at a bandwidth of 3.1 kHz, quantized and encoded and then transmitted at a bit rate of 64 kbit/s. A transmission rate of 2048 kbit/s results when 30 such coded channels are collected together into a frame along with the necessary signaling information. This so-called primary rate is used throughout the world. Only the USA, Canada and Japan use a primary rate of 1544 kbit/s, formed by combining 24 channels instead of 30. The growing demand for more bandwidth meant that more stages of multiplexing were needed throughout the world. A practically synchronous (or, to give it its proper name: plesiochronous) digital hierarchy is the result. Slight differences in timing signals mean that justification or stuffing is necessary when forming the multiplexed signals. Inserting or dropping an individual 64 kbit/s channel to or from a higher digital hierarchy requires a considerable amount of complex multiplexer equipment.

Towards the end of the 1980s, the so-called synchronous digital hierarchy (SDH) was introduced. This paved the way for a unified network structure on a worldwide scale, resulting in a means of efficient and economical network management for network providers. The networks can easily be adapted to meet the ever-growing demand for “bandwidth-hungry” applications and services.

The aim of this booklet is to provide an introduction to synchronous communications without going into details about “bits and bytes”. The following section looks at the current trends and changes in the transmission marketplace.

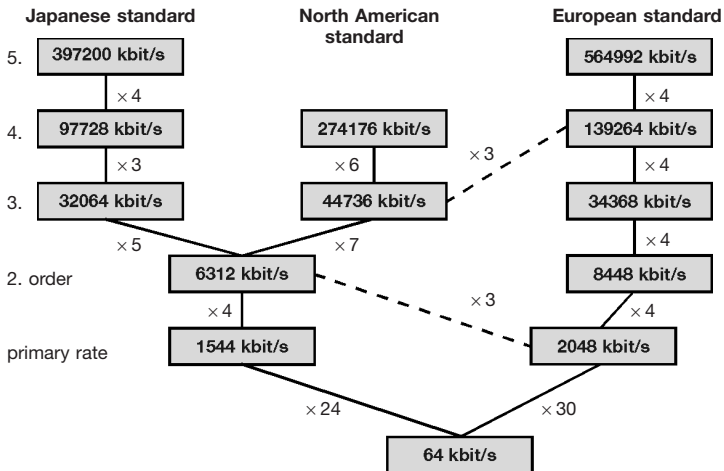

Figure 1: Summary of plesiochronous transmission rates

## What is the situation in the “synchronous” market?

Seen as a whole, the transmission market is in a growth period. Predictions are for an average global growth rate of around 5.5%. There are, however, vast regional differences. Growth in Western Europe is expected to be zero, but growth in Central and Eastern Europe is estimated at up to 22 %.

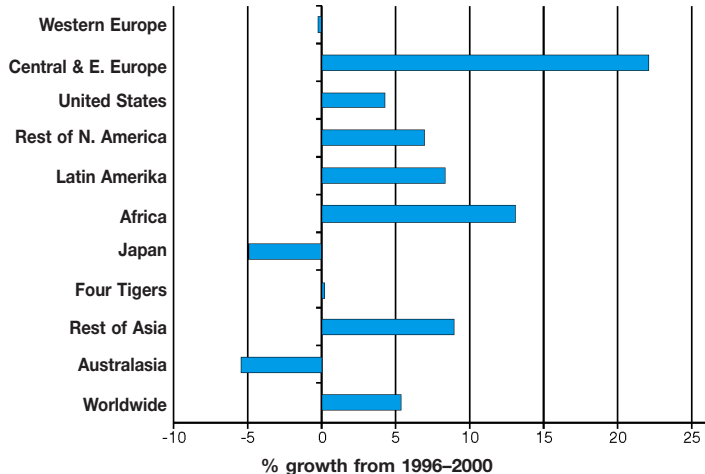
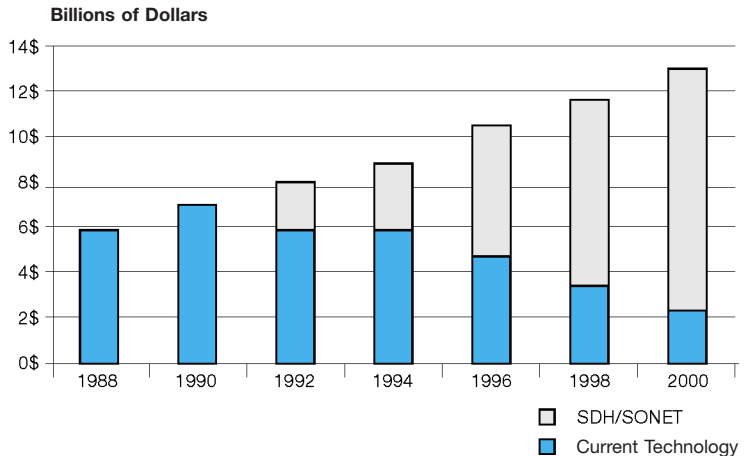

Figure 2: Global development in the market for synchronous communications  
(Source: Dataquest, 1997)

A further trend is the increasing proportion of SDH/SONET technology in the transmission market as a whole. Because the quality of SDH/SONET is distinct from that of previous technologies like PDH (see next section), more and more network providers are turning to this future-oriented method. The chart below shows clearly how the SDH/SONET market is developing in comparison with PDH.



*Figure 3: Global distribution of plesiochronous and synchronous technology as a proportion of total growth (Source: Dataquest, 1997)*

## Why SDH?

With the introduction of PCM technology in the 1960s, communications networks were gradually converted to digital technology over the next few years. To cope with the demand for ever higher bit rates, a multiplex hierarchy called the plesiochronous digital hierarchy (PDH) evolved. The bit rates start with the basic multiplex rate of 2 Mbit/s with further stages of 8, 34 and 140 Mbit/s. In North America and Japan, the primary rate is 1.5 Mbit/s. Hierarchy stages of 6 and 44 Mbit/s developed from this. Because of these very different developments, gateways between one network and another were very difficult and expensive to realize. The 1980s saw a start in the development of the synchronous digital hierarchy (SDH), with the intention of eliminating the disadvantages inherent in PDH. SDH brings the following advantages to network providers:

### 1. **High transmission rates**

Transmission rates of up to 10 Gbit/s can be achieved in modern SDH systems. SDH is therefore the most suitable technology for backbones, which can be considered as being the super highways in today's telecommunications networks.

### 2. **Simplified add & drop function**

Compared with the older PDH system, it is much easier to extract and insert low-bit rate channels from or into the high-speed bit streams in SDH. It is no longer necessary to demultiplex and then remultiplex the plesiochronous structure, a complex and costly procedure at the best of times.

### **3. High availability and capacity matching**

With SDH, network providers can react quickly and easily to the requirements of their customers. For example, leased lines can be switched in a matter of minutes. The network provider can use standardized network elements that can be controlled and monitored from a central location by means of a telecommunications network management (TMN) system.

### **4. Reliability**

Modern SDH networks include various automatic back-up and repair mechanisms to cope with system faults. Failure of a link or a network element does not lead to failure of the entire network which could be a financial disaster for the network provider.

These back-up circuits are also monitored by a management system.

### **5. Future-proof platform for new services**

Right now, SDH is the ideal platform for services ranging from POTS, ISDN and mobile radio through to data communications (LAN, WAN, etc.), and it is able to handle the very latest services, such as video on demand and digital video broadcasting via ATM that are gradually becoming established.



## 6. Interconnection

SDH makes it much easier to set up gateways between different network providers and to SONET systems. The SDH interfaces are globally standardized, making it possible to combine network elements from different manufacturers into a network. The result is a reduction in equipment costs as compared with PDH.

The driving force behind these developments is the growing demand for more bandwidth, better quality of service and reliability, coupled with the need to keep costs down in the face of increasing competition.

What about the future of transport networks? The trend is towards ever higher bit rates, such as STM-64 (time division multiplex, TDM). The current very high costs of such network elements are a retarding factor, though. The alternative is so-called dense wavelength division multiplexing (DWDM). This is a technology that makes multiple use of single-mode optical fibers possible. Various wavelengths are used as carriers for the digital signals and are transmitted through the fibers simultaneously. Currently-available systems permit transmission of 16 wavelengths between 1520 nm and 1580 nm over a single fiber. One STM-16 channel is transmitted at each wavelength, giving a capacity of some 40 Gbit/s per fiber. Expansion to 32 and even 64 wavelengths has already been announced.

Connected with the introduction of DWDM is the trend towards the “all-optical network”. Optical add/drop multiplexers are already available commercially and the first field trials are in progress for optical cross-

connects. In terms of the ISO-OSI layer model, this development basically means the introduction of an additional DWDM layer below the SDH layer (see figure 4). The future will therefore likely combine higher multiplex rates with the use of DWDM.

## **The synchronous digital hierarchy in terms of a layer model**

Telecommunications technologies are generally explained using so-called layer models. SDH can also be depicted in this way.

SDH networks are subdivided into various layers that are directly related to the network topology. The lowest layer is the physical layer, which represents the transmission medium. This is usually a glass fiber or possibly a radio-link or satellite link. The regenerator section is the path between regenerators. Part of the overhead (RSOH, regenerator section overhead) is available for the signaling required within this layer.

The remainder of the overhead (MSOH, multiplex section overhead) is used for the needs of the multiplex section. The multiplex section covers the part of the SDH link between multiplexers. The carriers (VC, virtual containers) are available as payload at the two ends of this section.

The two VC layers represent a part of the mapping process. Mapping is the procedure whereby the tributary signals, such as PDH and ATM signals are packed into the SDH transport modules. VC-4 mapping is used for 140 Mbit/s or ATM signals and VC-12 mapping is used for 2 Mbit/s signals.

The uppermost layer represents applications of the SDH transport network.

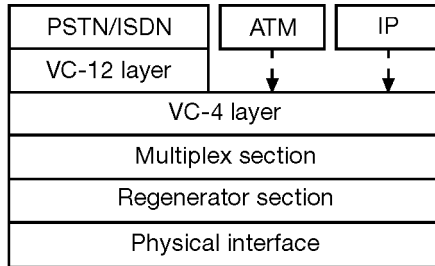

Figure 4: The SDH layer model

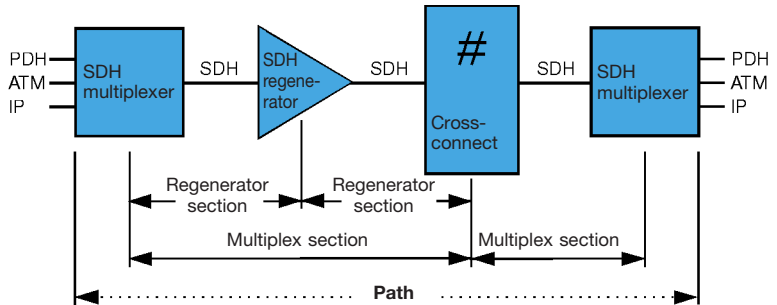

Figure 5: Path section designations

## What are the components of a synchronous network?

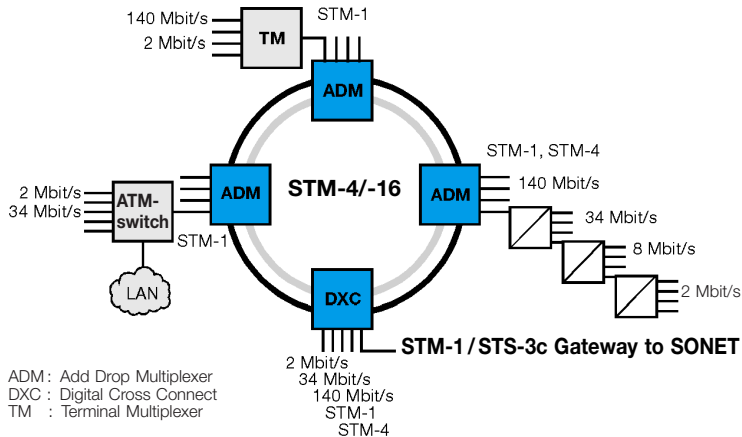

Figure 6: Schematic diagram of hybrid communications networks

Figure 6 is a schematic diagram of a SDH ring structure with various tributaries. The mixture of different applications is typical of the data transported by SDH. Synchronous networks must be able to transmit plesiochronous signals and at the same time be capable of handling future services such as ATM. All this requires the use of various different network elements; these are discussed in this section.

Current SDH networks are basically made up from four different types of network element. The topology (i.e. ring or mesh structure) is governed by the requirements of the network provider.

## Regenerators

Regenerators, as the name implies, have the job of regenerating the clock and amplitude relationships of the incoming data signals that have been attenuated and distorted by dispersion. They derive their clock signals from the incoming data stream. Messages are received by extracting various 64 kbit/s channels (e.g. service channels E1, F1) in the RSOH (regenerator section overhead). Messages can also be output using these channels.

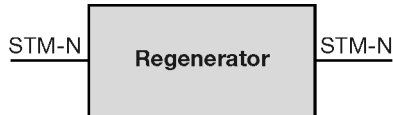

## Terminal multiplexers

Terminal multiplexers are used to combine plesiochronous and synchronous input signals into higher bit rate STM-N signals.



## Add/drop multiplexers (ADM)

Plesiochronous and lower bit rate synchronous signals can be extracted from or inserted into high speed SDH bit streams by means of ADMs. This feature makes it possible to set up ring structures, which have the advantage that automatic back-up path switching is possible using elements in the ring in the event of a fault.

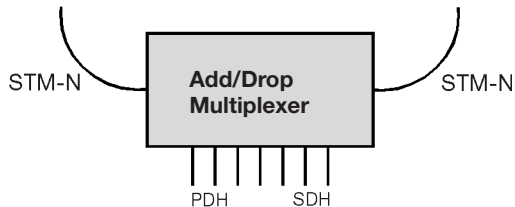

## Digital cross-connects (DXC)

This network element has the widest range of functions. It allows mapping of PDH tributary signals into virtual containers as well as switching of various containers up to and including VC-4.

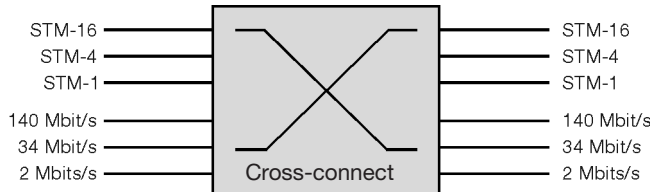

## **Network element management**

The telecommunications management network (TMN) is considered as a further element in the synchronous network. All the SDH network elements mentioned so far are software-controlled. This means that they can be monitored and remotely controlled, one of the most important features of SDH. Network management is described in more detail in the section “TMN in the SDH network”.

Optical fibers are the physical medium most used for SDH networks. The advantage of optical fibers is that they are not susceptible to interference and they can transmit at very high speeds (also see under DWDM). The disadvantage is the relatively high cost of procurement and installation. Single-mode fibers for the first and second optical windows (1310 nm and 1550 nm) are the medium of choice.

A further possible method of transmitting SDH signals is via radio link or satellite paths. These are particularly suitable for setting up transmission paths quickly, or as a part of a mobile radio network or in difficult terrain. Disadvantages here are the limited bandwidth (currently up to STM-4) and the relatively complex business of linking such paths into the network management system.



## The STM-1 frame format

A frame with a bit rate of 155.52 Mbit/s is defined in ITU-T Recommendation G.707. This frame is called the synchronous transport module (STM). Since the frame is the first level of the synchronous digital hierarchy, it is known as STM-1. Figure 7 shows the format of this frame. It is made up from a byte matrix of 9 rows and 270 columns. Transmission is row by row, starting with the byte in the upper left corner and ending with the byte in the lower right corner. The frame repetition rate is 125  $\mu$ s. Each byte in the payload represents a 64 kbit/s channel.

The STM-1 frame is capable of transporting any PDH tributary signal ( $\leq 140$  Mbit/s).

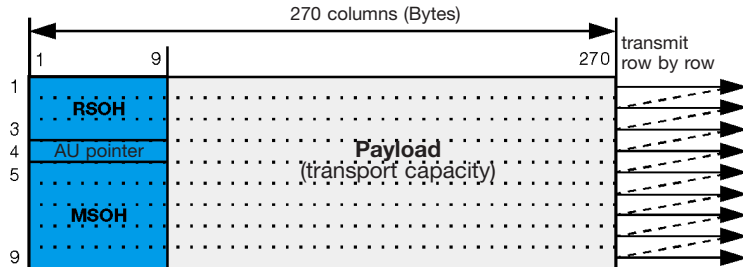

Figure 7: Schematic diagram of STM-1 frame

## Section overhead (SOH)

The first 9 bytes in each of the 9 rows are called the overhead. G.707 makes a distinction between the regenerator section overhead (RSOH) and the multiplex section overhead (MSOH). The reason for this is to be able to couple the functions of certain overhead bytes to the network architecture. The table below describes the individual functions of the bytes.

### STM-1 SOH

A1	A1	A1	A2	A2	A2	J0	X	X
B1	●	●	E1	●		F1	X	X
D1	●	●	D2	●		D3		
AU pointer								
B2	B2	B2	K1			K2		
D4			D5			D6		
D7			D8			D9		
D10			D11			D12		
S1					M1	E2		

X Reserved for national use

● Media-dependent use (radio-link, satellite)

Figure 8: Overview of STM-1 overhead

<b>Overhead byte</b>	<b>Function</b>
A1, A2	Frame alignment
B1, B2	Quality monitoring, parity bytes
D1 ... D3	Q <sub>ECC</sub> network management
D4 ... D12	Q <sub>ECC</sub> network management
E1, E2	Voice connection
F1	Maintenance
J0 (C1)	Trace identifier
K1, K2	Automatic protection switching (APS) control
S1	Clock quality indicator
M1	Transmission error acknowledgment

*Table 1: Overhead bytes and their functions*

## **Path overhead**

The path overhead (POH) plus a container forms a virtual container. The POH has the task of monitoring quality and indicating the type of container. The format and size of the POH depends on the container type. A distinction is made between two different POH types:

### VC-3/4 POH

J1	Path indication
B3	Quality monitoring
C2	Container format
G1	Transmission error acknowledgment
F2	Maintenance
H4	Superframe indication
F3	Maintenance
K3	Automatic protection switching
N1	Tandem connection monitoring

The VC-3/4 POH is the high-order path overhead. This path is for transporting 140 Mbit/s, 34 Mbit/s and ATM signals.

### VC-11/12 POH

V5	Indication and error monitoring
J2	Path indication
N2	Tandem connection monitoring
K4	Automatic protection switching

The VC-11/12 POH is used for the low-order path. ATM signals and bit rates of 1.544 Mbit/s and 2.048 Mbit/s are transported within this path.

## How are PDH and ATM signals transported by SDH?

The heterogeneous nature of modern network structures has made it necessary that all PDH and ATM signals are transported over the SDH network. The process of matching the signals to the network is called mapping. The container is the basic package unit for tributary channels. A special container (C-n) is provided for each PDH tributary signal. These containers are always much larger than the payload to be transported. The remaining capacity is used partly for justification (stuffing) in order to equalize out timing inaccuracies in the PDH signals. Where synchronous tributaries are mapped, fixed fill bytes are inserted instead of justification bytes. A virtual container (VC-n) is made up from the container thus formed together with the path overhead (POH). This is transmitted unchanged over a path through the network. The next step towards formation of a complete STM-N signal is the addition of a pointer indicating the start of the POH. The unit formed by the pointer and the virtual container is called an administrative unit (AU-n) or a tributary unit (TU-n).

Several TUs taken together form a tributary unit group (TUG-n); these are in turn collected together into a VC. One or more AUs form an administrative unit group (AUG). Finally, the AUG plus the section overhead (SOH) forms the STM-N.

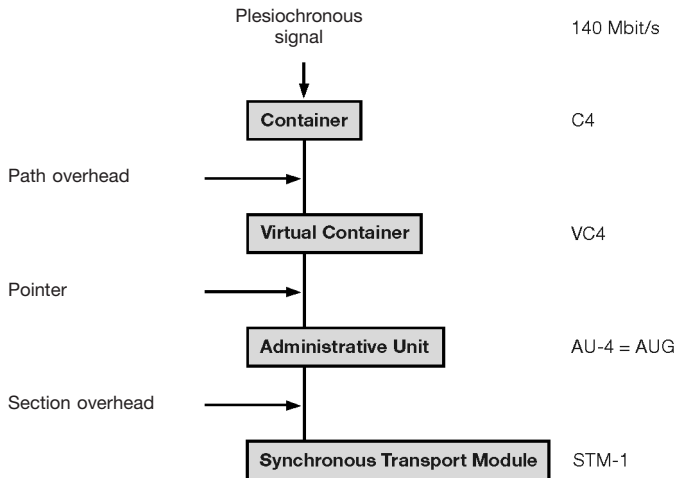

Figure 9: Inserting a 140 Mbit/s tributary into an STM-1

ATM signals can be transported in the SDH network in C11, C12, C3 and C4 containers. Since the container transport capacity does not meet the continually increasing ATM bandwidth requirement, methods have been developed for transmitting the ATM payload in a multiple (n) C-4 (virtual or contiguous concatenation). As an example, a quadruple C-4 can be transmitted in a STM-4 (see the section on “Contiguous concatenation”).

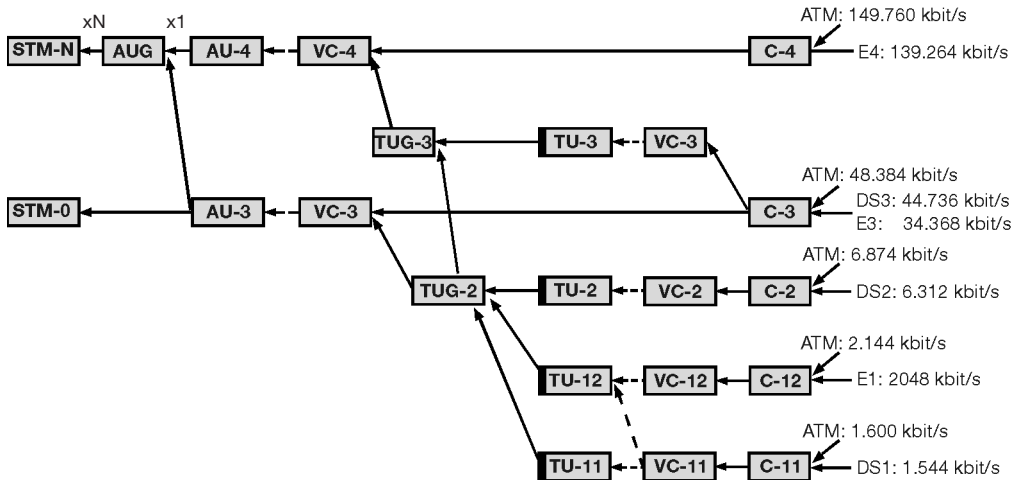

Figure 10: Mapping in SDH

Figure 10 is a summary of the mappings that are currently possible according to ITU-T Recommendation G.707 and the ATM mapping recommendations. Of interest in this context is the so-called sub-STM or STM-0 signal. This interface is used in SDH/SONET links and in radio-link and satellite connections. The STM-0 bit rate is 51.84 Mbit/s.

## What is the difference between SDH and SONET?

As already mentioned, SDH is the synchronous digital hierarchy that is used everywhere except in the USA, Canada and Japan. SONET (synchronous optical network) is the American equivalent of SDH. Specification of this transmission technology in the USA began as far back as 1985. The SONET base bit rate is 51.84 Mbit/s and is designated STS-1 (synchronous transport signal). If this bit rate is transmitted over an optical cable system, the signal is designated OC-1 (optical container). Other levels in the hierarchy are:

<b>SONET signals</b>		<b>Bit rates</b>	<b>Equivalent SDH signal</b>
STS-1	OC-1	51.84 Mbit/s	STM-0
STS-3	OC-3	155.52 Mbit/s	STM-1
STS-9*	OC-9*	466.56 Mbit/s	
STS-12	OC-12	622.08 Mbit/s	STM-4
STS-18*	OC-18*	933.12 Mbit/s	
STS-36*	OC-36*	1244.16 Mbit/s	
STS-48*	OC-48	2488.32 Mbit/s	STM-16
STS-192*	OC-192	9953.28 Mbit/s	STM-64

(\* These hierarchy levels are not normally used and are mentioned only for the sake of completeness)



The hierarchy levels basically match the plesiochronous bit rates that are in common use in these countries. Of all the levels mentioned above, only STS-1, OC-3, OC-12, OC-48 and OC-192 are currently utilized. As the table indicates, there are points where transition between the two systems (SDH and SONET) are possible. Matching is relatively simple, as the gateway problem was taken into consideration when SDH was specified. It is only necessary to adjust certain overhead bytes. The SONET terminology is, however, quite different. For example, the packing unit is called a virtual tributary (VT-n) instead of a container.

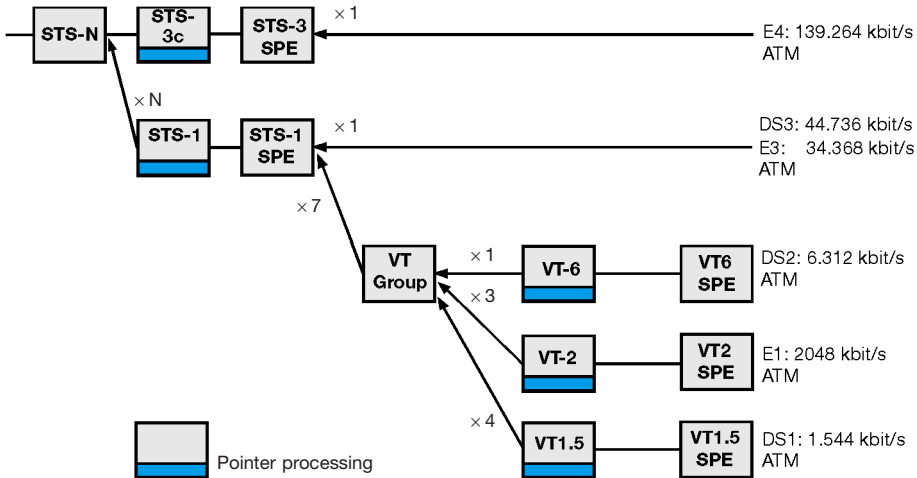

Figure 11: SONET multiplexing scheme

## Pointer procedures

The use of pointer procedures also gives synchronous communications a distinct advantage over the plesiochronous hierarchy. Pointers are used to localize individual virtual containers in the payload of the synchronous transport module. The pointer may directly indicate a single VC-n virtual container from the upper level of the STM-1 frame. Chained pointer structures can also be used. The AU-4 pointer initially indicates the VC-4 overhead. Three further pointers are located at fixed positions in the VC-4; these indicate the start of the three VC-3 virtual containers relative to the VC-4. Figure 12 describes the pointer procedure using C3 mapping as an example.

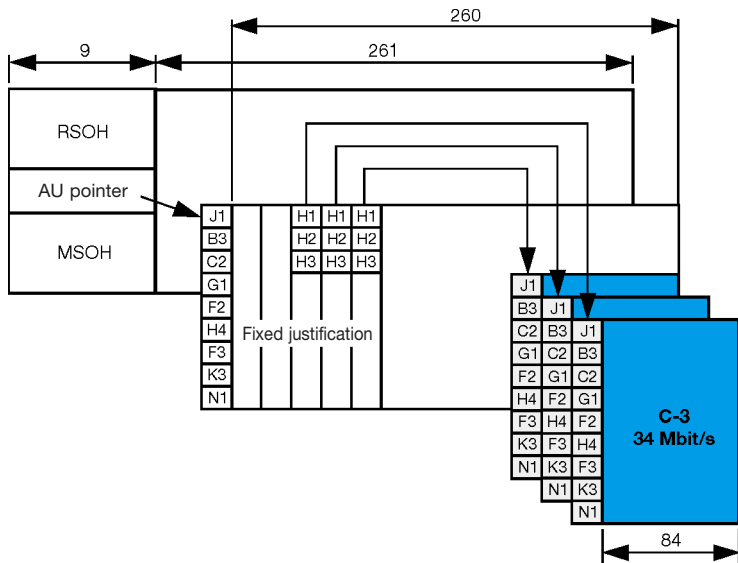

Figure 12: Schematic diagram of C-3 mapping

SDH multiplexers are controlled from a highly accurate central clock source running at 2.048 MHz. Pointer adjustment may be necessary if phase variations occur in the real network or if the connection is fed through the networks of different providers. The AU pointer can be altered in every fourth frame with prior indication. The virtual container is then shifted by precisely 3 bytes. Pointer activity is an indication of clock variations within a network.

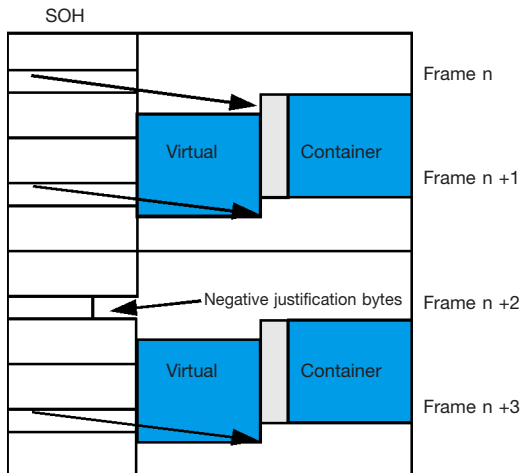

Figure 13: Negative pointer justification

If the pointer is shifted to a later point in time (to the right in the diagram), the 3 bytes immediately preceding it will be ignored. If the transmitting source is in advance of the actual clock, space for extra capacity must be provided. This takes place at the pointer position into which three bytes are slipped each time. If a further clock adjustment is not made, this configuration will be propagated throughout the network. This allows, on the one hand, the free insertion in time of user signals into the next higher frame structure in the form of virtual containers without the need for larger buffers. On the other hand, changes in the phase location of the virtual container relative to the superior frame can be corrected by appropriate pointer actions. Such changes and shifts in phase can be caused by changes in propagation delay in the transmission medium or by non-synchronous branches in the real network. When a multiplex bundle is resolved, pointer procedures make it possible to immediately locate every user channel from each STM-N frame, which considerably simplifies drop and insert operations within a network node. In contrast, complete demultiplexing of every level of a pleisochronous hierarchy signal is required in order to access a particular tributary channel.

## **AU-4 contiguous concatenation**

This mechanism is provided to allow bit rates in excess of the capacity of the C-4 container to be transmitted. For example, the AU-4-4c is intended for transporting B-ISDN bit rates. The advantage of this method is that the payload must not be split up, since a virtually contiguous container is formed within an STM-4. The payloads of several consecutive AU-4s are linked by setting all the pointers to a fixed value, the concatenation indicator (CI), with the exception of the pointer for the first AU-4. If pointer activity becomes necessary, this takes place for all concatenated AU-4s equally. Figure 14 shows how the payload of ATM cells can be transmitted as a whole.

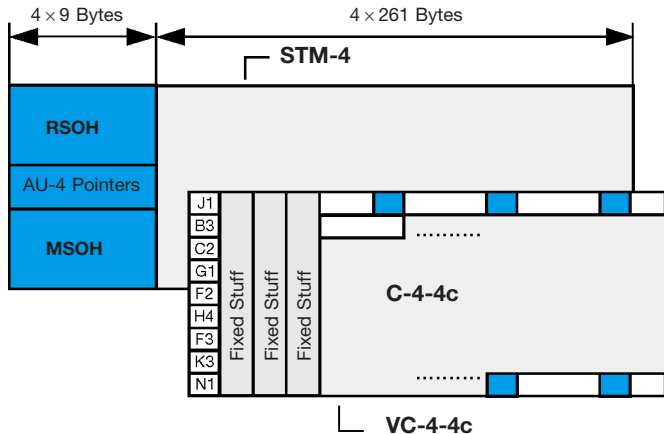
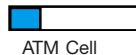

Figure 14: Virtual concatenation

The first pointer indicates J1  
 All other pointers are set to concatenation indication (C)





## AU-4 virtual concatenation

If the cross-connects in the SDH network are unable to switch complete VC-4-4cs, the above-mentioned method cannot be used to transmit ATM payloads. On the transmit side, four complete VC-4s with four identical pointer values are combined into an AUG. The individual VC-4s are transported independently through the network. Ensuring the integrity of the payload is the task of the network element on the receiving side. This reassembles the payload of the individual virtually concatenated VC-4s into a unit, even if different pointer values are present.

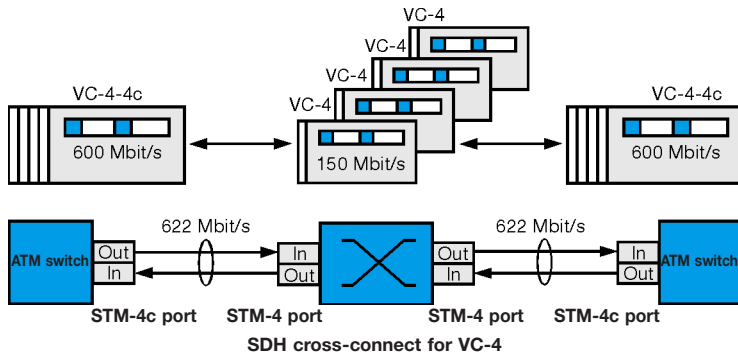

Figure 15: Principle of contiguous concatenation

## **Transmission at higher hierarchy levels**

To achieve higher bit rates, AU-3/4s are multiplexed into STM-N frames. The following hierarchy levels are defined in SDH:

STM-1	155.52 Mbit/s
STM-4	622.08 Mbit/s
STM-16	2488.32 Mbit/s
STM-64	9953.28 Mbit/s

The STM-N frame structures are basically N times the STM-1 structure. For example, the STM-4 overhead is four times the size of the STM-1 overhead. The SOH content is specified for each stage individually. For this, the A1, A2 and B2 bytes are formed N times.

## **Error and alarm monitoring**

### **SDH alarms**

Large numbers of alarm and error messages are an integral part of SDH networks. In SDH, these are referred to as defects and anomalies, respectively. They are coupled to network sections and the corresponding overhead information. The advantage of this detailed information is illustrated as follows:

Complete failure of a circuit results, for example, in a LOS alarm (loss of signal) in the receiving network element. This alarm triggers a complete chain of subsequent messages in the form of AIS (alarm indication signals; see figure 16). The transmitting side is informed of the failure by the return of an RDI alarm (remote defect indication). The alarm messages are transmitted in fixed bytes in the SOH or POH. For example, byte G1 is used for the HP-RDI alarm.

## STMN Alarm Scheme

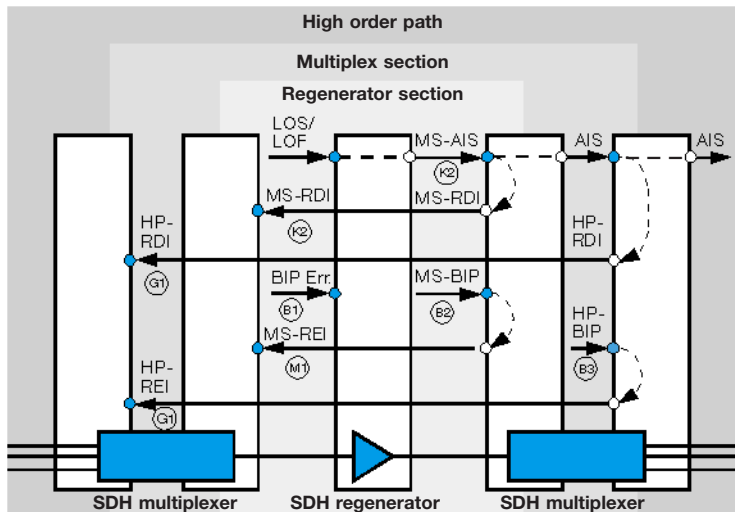

Figure 16: Overview of major defects and anomalies

If the received signal contains bit errors, the sensor indicates BIP errors. Since this is not the same as a complete failure of the circuit, the alarm here is referred to as an anomaly that is indicated back in the direction of transmission. The return message is called a REI (remote error indication). Table 2 is a list of all possible defects and anomalies and the corresponding bytes and their meanings.

<b>SDH</b>	<b>Description</b>	<b>OH Byte</b>
LOS	Loss of signal	
TSE	Test sequence error (bit error)	
LSS	Loss of sequence synchronization	
AIS	Alarm indication signal	
<b>Regenerator section</b>		
OOF	Out of frame	A1, A2
LOF	Loss of frame	A1, A2
B1	Regenerator section error monitoring	B1
RS-TIM	RS trace identifier mismatch	J0

*Table 2: Anomalies and defects in SDH*

<b>Multiplex section</b>		
MS-AIS	Multiplex section AIS	K2
MS-RDI	Mux section remote defect indication	K2
MS-REI	Mux section remote error indication	M1
B2 (24 bits)	Mux section error monitoring	B2
<b>Administrative unit</b>		
AU-LOP	Loss of AU pointer	H1, H2
AU-NDF	New data flag AU pointer	
AU-AIS	Administrative unit AIS	AU incl. H1, H2
AU-PJE	AU pointer justification event	H1, H2
<b>High order path</b>		
HP-UNEQ	HO path unequipped	C2
HP-RDI	HO remote defect indication	G1
HP-REI	HO remote error indication	G1
HP-TIM	HO path trace identifier mismatch	J1
HP-PLM	HO path payload label mismatch	C2
B3	HO path error monitoring	B3

<b>Tributary unit</b>		
TU-LOP	Loss of TU pointer	V1, V2
TU-NDF	New data flag TU pointer	
TU-AIS	TU alarm indication signal	TU incl. V1 to V4
TU-LOM	TU loss of multiframe	H4
<b>Low order path</b>		
LP-UNEQ	LO path unequipped	V5
LP-RDI	LO path remote defect indication	V5
LP-REI	LO path remote error indication	V5
LP-RFI	LO path remote failure indication	V5
LP-TIM	LO path trace identifier mismatch	J2
LP-PLM	LO path payload label mismatch	V5
BIP-2	LO path error monitoring (VC-11/-12)	V5
B3	LO path error monitoring (VC-3)	B3

## **Back-up network switching**

Modern society is virtually completely dependent on communications technology. Trying to imagine a modern office without any connection to telephone or data networks is like trying to work out how a laundry can operate without water. Network failures, whether due to human error or faulty technology, can be very expensive for users and network providers alike. As a result, the subject of so-called fall-back mechanisms is currently one of the most talked about in the SDH world. A wide range of standardized mechanisms is incorporated into synchronous networks in order to compensate for failures in network elements.

## **Automatic protection switching (APS)**

Two basic types of protection architecture are distinguished in APS. One is the linear protection mechanism used for point-to-point connections. The other basic form is the so-called ring protection mechanism which can take on many different forms. Both mechanisms use spare circuits or components to provide the back-up path. Switching is controlled by the overhead bytes K1 and K2.

## **Linear protection**

The simplest form of back-up is the so-called 1 + 1 APS. Here, each working line is protected by one protection line. If a defect occurs, the protection agent in the network elements at both ends switch the circuit over to the protection line. The switchover is triggered by a defect such as LOS. Switching at the far end is initiated by the return of an acknowledgment in the backward channel.



1+1 architecture includes 100% redundancy, as there is a spare line for each working line. Economic considerations have led to the preferential use of 1:N architecture, particularly for long-distance paths. In this case, several working lines are protected by a single back-up line. If switching is necessary, the two ends of the affected path are switched over to the back-up line.

The 1+1 and 1:N protection mechanisms are standardized in ITU-T Recommendation G.783.

The reserve circuits can be used for lower-priority traffic, which is simply interrupted if the circuit is needed to replace a failed working line.

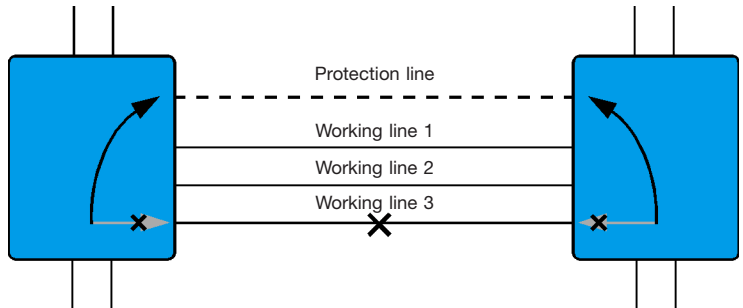

Figure 17: 1:3 linear protection

## Ring protection

The greater the communications bandwidth carried by optical fibers, the greater the cost advantages of ring structures as compared with linear structures. A ring is the simplest and most cost-effective way of linking a number of network elements.

Various protection mechanisms are available for this type of network architecture, only some of which have been standardized in ITU-T Recommendation G.841. A basic distinction must be made between ring structures with unidirectional and bi-directional connections.

## Unidirectional rings

Figure 18 shows the basic principle of APS for unidirectional rings. Let us assume that there is an interruption in the circuit between the network elements A and B. Direction y is unaffected by this fault. An alternative path must, however, be found for direction x. The connection is therefore switched to the alternative path in network elements A and B. The other network elements (C and D) switch through the back-up path. This switching process is referred to as line switched. A simpler method is to use the so-called path switched ring (see figure 18). Traffic is transmitted simultaneously over both the working line and the protection line. If there is an interruption, the receiver (in this case A) switches to the protection line and immediately takes up the connection.

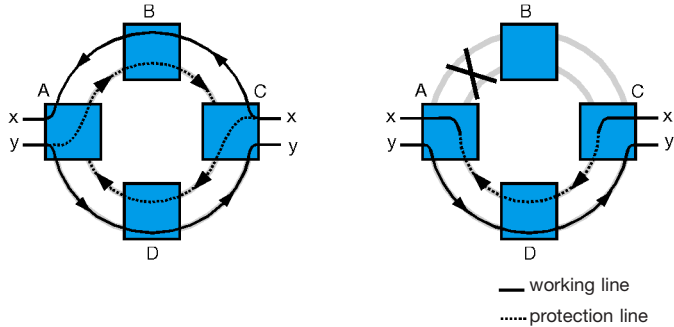

Figure 18: Two fiber unidirectional path switched ring

### Bi-directional rings

In this network structure, connections between network elements are bi-directional. This is indicated in figure 19 by the absence of arrows when compared with figure 18. The overall capacity of the network can be split up for several paths each with one bi-directional working line, while for unidirectional rings, an entire virtual ring is required for each path. If a fault occurs between neighboring elements A and B, network element B triggers protection switching and controls network element A by means of the K1 and K2 bytes in the SOH.

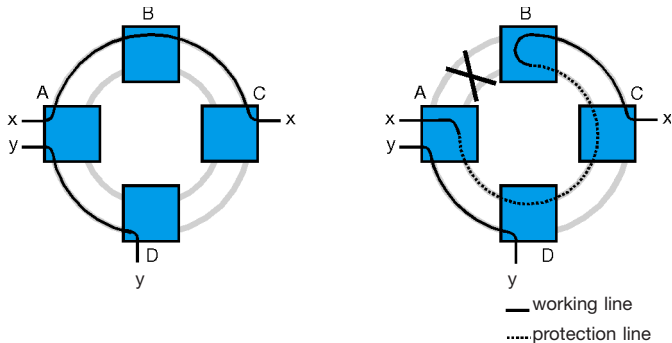
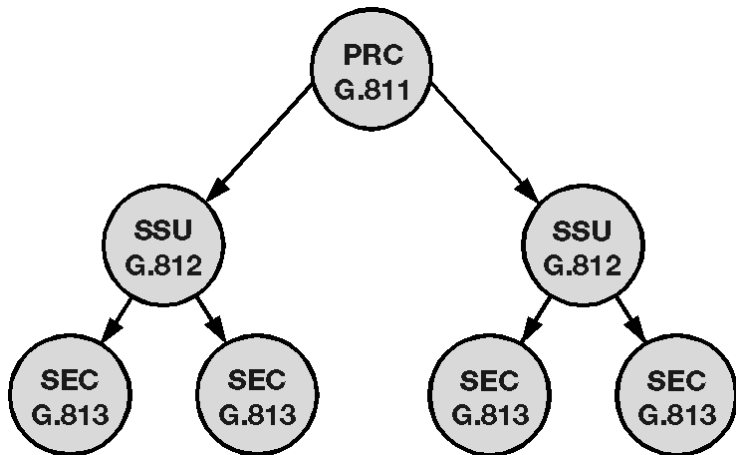

Figure 19: Two fiber bi-directional line-switched ring (BLSR)

Even greater protection is provided by bi-directional rings with 4 fibers. Each pair of fibers transports working and protection channels. This results in 1:1 protection, i.e. 100 % redundancy. This improved protection is coupled with relatively high costs.

## Synchronization

Synchronous is the first word in the term SDH for a very good reason. If synchronization is not guaranteed, considerable degradation in network function, and even total failure of the network can be the result. To avoid this worst case scenario, all network elements are synchronized to a central clock. This central clock is generated by a high-precision primary reference clock (PRC) unit conforming to ITU-T Recommendation G.811. This specifies an accuracy of  $1 \times 10^{-11}$ . This clock signal must be distributed throughout the entire network. A hierarchical structure is used for this; the signal is passed on by the subordinate synchronization supply units (SSU) and synchronous equipment clocks (SEC). The synchronization signal paths can be the same as those used for SDH communications.



*Figure 20: Clock supply hierarchy structure*

The clock signal is regenerated in the SSUs and SECs with the aid of phase-locked loops. If the clock supply fails, the affected network element switches over to a clock source with the same or lower quality, or if this is not possible, it switches to hold-over mode. In this situation, the clock signal is kept relatively accurate by controlling the oscillator by applying the stored frequency correction values for the previous hours and taking the temperature of the oscillator into account. Clock

“islands” must be avoided at all costs, as these would drift out of synchronization with the passage of time and the total failure disaster would be the result. Such islands are prevented by signaling the network elements with the aid of synchronization status messages (SSM, part of the S1 byte). The SSM informs the neighboring network element about the status of the clock supply and is part of the overhead.

Special problems arise at gateways between networks with independent clock supplies. SDH network elements can compensate for clock offsets within certain limits by means of pointer operations. Pointer activity is thus a reliable indicator of problems with the clock supply.

## **TMN in the SDH network**

The principle of telecommunications management network (TMN) technology was established in 1989 with the publication by the CCITT (now ITU-T) of Recommendation M.3010. The functions of a TMN are summed up in the expression “Operation, administration, maintenance and provisioning” (OAM&P). This includes monitoring the network performance and the checking of error messages, among other things. To provide these functions, TMN uses object-oriented techniques based on the OSI reference model. The TMN model comprises one manager handling several agents. The agents in turn each handle several managed objects (MO). The manager is included in the operating system (OS) which forms the “control center” for the network as a whole or in part. In a SDH network, the agents are located in the network elements (NE), such as switches, etc. A MO may be a physical unit (e.g. a plug-in card, multiplex section, etc.) but can also occur as a logical element (e.g. a virtual connection).

TMN also distinguishes between logical management units. For example, one management unit operates at network level, handling individual NEs. Another management unit operates at the service level, e.g. for monitoring billing charges.

These tasks are performed in modern telecommunications networks by using the common management information protocol (CMIP). The simple network management protocol (SNMP) is often mentioned in this context; this is basically a simplified form of CMIP. SNMP is mainly used in data communications, however, and cannot cope with the requirements of large telecommunications networks. The Q3 interface, which is where the exchange of data between manager and agent takes place, is the



point of reference for CMIP. CMIP is also used where several TMNs or their managers are linked together via the X interface. Since large quantities of data are not generally required for exchanging information in the TMN, the capacity of the embedded communication channels (ECC) or data communication channels (DCC) is sufficient when managing SDH networks. Channels D1 to D3 with a capacity of 192 kbit/s ( $DCC_P$ ) are used for SDH-specific NE management. Channels D4 to D12 with a capacity of 576 kbit/s ( $DCC_M$ ) can be used for non SDH-specific purposes.

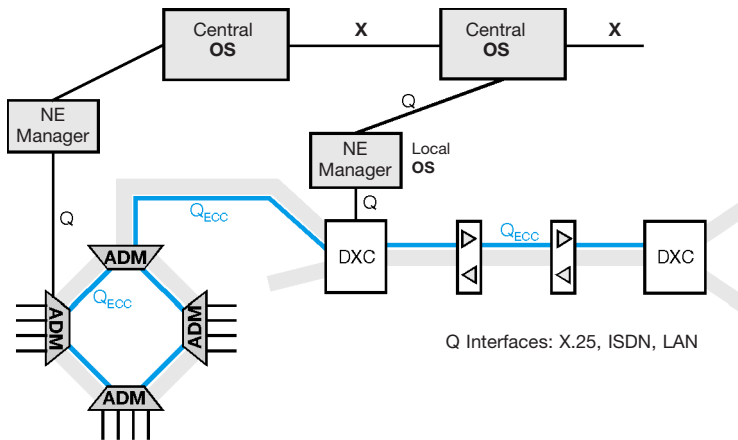

Figure 21: TMN overlay

To distinguish the implementation in the section overhead (SOH) data channels from the Q interface, the term QECC protocol is used. To summarize, such networks are called SDH management networks (SMN); these are primarily responsible for managing network elements. SMNs can also be subdivided into sub-networks (SMS).

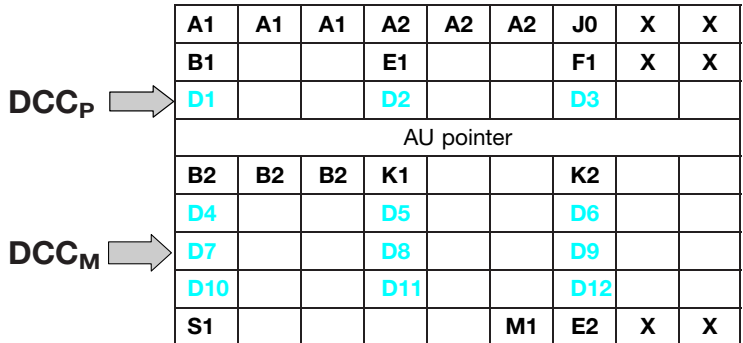

Figure 22: D bytes in the STM-1 SOH

## SDH measurement tasks

Why are separate measurement procedures required for today's TMN-controlled SDH networks? Is it in fact possible to do without test equipment in general? These or similar questions may arise in your mind, now that you are familiar with the way that SDH networks are constructed and with the basic principles governing their functions. Although trouble-free operation of all network elements should have been guaranteed by standardization on the part of various bodies (ITU, ETSI, ANSI, Bellcore), problems still arise, particularly when network elements from different sources are linked together. Transmission problems also occur at gateways between networks run by different providers. The measurement facilities built in to the system provide only a rough idea of the location of a fault. Separate measuring equipment, in contrast, is of much greater usefulness, particularly when it comes to monitoring individual channels. Much more data relevant to clearing the fault can be obtained. The only areas that are covered by both network management and measurement procedures are long term analysis and system monitoring.

Separate measuring equipment of course finds further application in the fields of research and development, production and installation. These areas in particular require test equipment with widely differing specifications.

Take production and installation as an example: Systems manufacturers configure their network elements or entire networks according to customer requirements and use measuring techniques to check that every-

thing operates as it should. Next, the equipment is installed on the customer's site and put into operation. Test equipment is essential at this stage to eliminate any faults that may have occurred during production and installation and to verify correct function. Such test equipment needs to be portable and robust, and capable of performing test sequences in order to reliably and quickly reproduce repeat measurements and long-term analyses.

A further example, network providers. Fault clearance and maintenance are the main uses here for measuring equipment. The continuing process of network optimization also plays a major role. Here, too, test equipment must be portable; it must also be reasonably priced and suitable for in-service and out-of-service measurements, and provide users with a rapid and easily interpreted display of the results. Generally speaking, the following measurement tasks must be handled by SDH test equipment:

- Mapping analysis
- Alignment of port interfaces
- Measurements with structured test signals
- Measurements on add/drop multiplexers
- Delay measurements
- Testing of automatic protection switching (APS)
- Simulation of pointer activity

- In-service SDH measurements
  - Alarm analysis
  - Path trace monitoring
  - Pointer analysis
  - Checking the sensors built-in to the system
  - Drop and insert measurements
  - Checking network synchronization
  - Measurements on the TMN interface
- Quality evaluation as per G.821, G.826 and M.2100
- Jitter and wander analysis

Some of these measurements are discussed in more detail below.

## **Sensor tests**

These measurements are performed in order to check the reaction of system components to defects and anomalies. Anomalies are faults such as parity errors. Defects result in the interruption of a connection. For example, a network element must react to a LOS (loss of signal) alarm by sending AIS (alarm indication signal) to the subsequent network elements and transmitting a RDI (remote defect indication) signal in the return path (compare figure 10).

## **APS time measurements**

A special mechanism operates in SDH networks in the event of a fault. The faulty link is automatically re-routed over a back up circuit (see “Automatic protection switching (APS)”, above). This function is controlled using overhead bytes K1 and K2. Switching over to the protection line must take place in less than 50 ms. To ensure that this is so, external test equipment is needed.

This is used to measure the response time (i.e. loss of a specific test pattern or triggering a pre-set alarm) when a connection is intentionally interrupted (see figure 23). The measurement is very important, as a delayed response can result in considerable degradation in performance and even to a total failure of the network and major loss of income for the network provider.

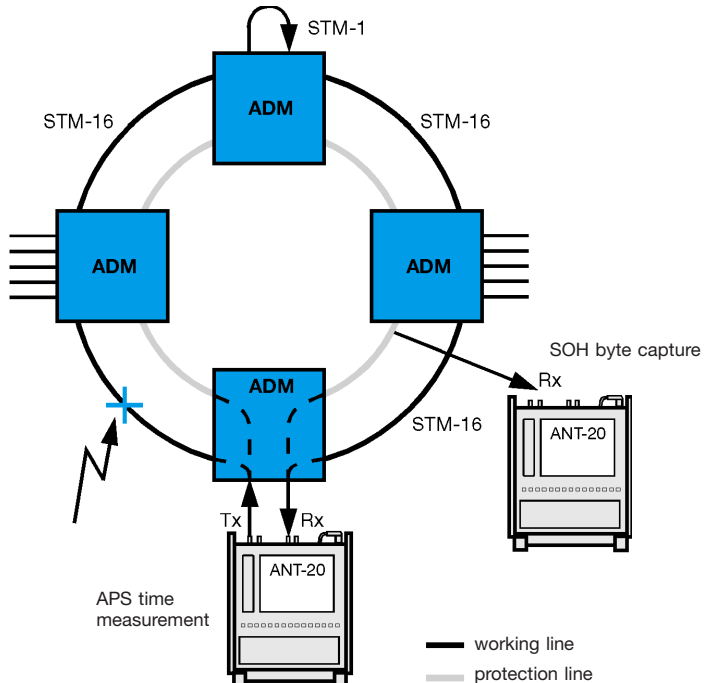

Figure 23: Checking APS response time

## **G.821, G.826 and M.2100 performance analysis**

The quality of digital links is determined with the aid of bit error ratio tests (BERT). The results of such measurements must, however, be classified in some way, not least because the quality of a transmission path is often the subject of a contract between the network provider and the telecommunications user. For this reason, an objective means of classifying a line as either “good” or “bad” is required. The ITU-T Recommendations G.821, G.826 and M.2100 are internationally recognized standards that specify these parameters.

### **G.821**

This Recommendation was originally specified for international circuit-switched  $n \times 64$  kbit/s connections and expanded to include higher bit rates as time went on. A hypothetical reference connection is the basis used for determining quality parameters; this comprises an international long-distance segment, a national segment and a subscriber access segment.

G.821 definitions:

- Errored second (ES): A one-second time interval in which one or more bit errors occurs.
- Severely errored second (SES): A one-second time interval in which the bit error ratio exceeds  $10^{-3}$ .
- Unavailable second (US): A circuit is considered to be unavailable from the first of at least ten consecutive SES. The circuit is available from the first of at least ten consecutive seconds which are not SES.



The original version of G.821 also included:

- Degraded minute (DM): A one-minute time interval in which the bit error ratio exceeds  $10^{-6}$ .

Derived parameter:

- Error-free second (EFS): A one-second time interval in which no bit errors occur.

The disadvantage of this method is that it relies on the evaluation of bit errors and so the test channel must be taken out of service to perform the measurement.

## G.826

This Recommendation, issued in 1993, takes higher bit rates into account and allows in-service measurement as it relies on the evaluation of block errors.

G.826 definitions:

- Errored second (ES): A one-second time interval containing one or more errored blocks.
- Errored block (EB): A block containing one or more errored bits.
- Severely errored second (SES): A one-second time interval in which more than 30 % of the blocks are errored or which contains at least one severely disturbed period (SDP).
- Background block error (BBE): An errored block that is not a SES.
- Unavailable second (US): see under G.821, above.

The results are referred to the measurement time. This gives the following error parameters: Errored seconds ratio (ESR), severely errored seconds ratio (SESR) and background block error ratio (BBER). The specified quality requirements refer to a particular path. The recommended measurement time for G.821 and G.826 is 30 days.

## **M.2100**

Recommendation M.2100 specifically applies to commissioning and maintenance. Commissioning consists of a 15-minute line up phase followed by a 24-hour in-service measurement. Once the line up phase is completed successfully, errors may occur within certain limits. If this is the case, the line remains in service, but must continue to be monitored for a further 7 days. The measurement procedures are defined in M.2110 and M.2120. The limit values are derived from the performance parameters specified in G.821 and G.826.

## **Tandem connection monitoring (TCM)**

Overhead byte B3 is used to monitor the quality of a path. It is evaluated at the start and end of the path. However, it is becoming increasingly necessary to determine the quality of individual segments of a path which might pass through the networks of different providers. In such cases, it is especially important to be able to demonstrate that high quality is guaranteed in one's own network. When a fault occurs, the question of who bears the responsibility and the costs of making the repairs is one that needs answering.

Tandem connection monitoring allows monitoring of the performance of path segments with the aid of the N bytes in the POH. The high-order and low-order POH parity bytes are evaluated by the network elements. The number of errors detected is indicated to the end of the TCM using the N1 or N2 byte. This error count is then recompared with the number of parity errors detected at the end of the TCM. The difference is the number of errors occurring within the TCM.

## **Jitter measurements**

The term jitter refers to phase variations in a digital signal. Put another way, the edges of the digital signal may differ from the expected ideal positions in time. Jitter is described in terms of its amplitude (expressed in unit intervals, UI) and its frequency. If the jitter frequency is below 10 Hz, the term used is wander. Signals that are affected by jitter cannot be sampled accurately; in an extreme situation, this might result in misinterpretation of the input signal. This results in single errors or error bursts and a corresponding degradation in transmission quality. Jitter and wander can also be the cause of buffer underflow or overflow,

which leads to bit slips. The theoretical limit of correct sampling at high jitter frequencies is half the bit width. Distortion and additive noise means that the actual limit must be set much lower than this. What causes jitter? The clock sources for network elements such as regenerators and add/drop multiplexers are one possible cause. Various types of jitter are differentiated as shown in the following table.

<b>Jitter type</b>	<b>Cause</b>
Mapping jitter	Mapping of asynchronous tributary signals into synchronous transport signals requires bit stuffing in order to match the bit rates. This results in mapping jitter when the signal is demapped.
Pointer jitter	If the SDH transmission bit rates are not synchronous, the timing of the transported payload containers must be matched to the outgoing frame. This is done by incrementing or decrementing the pointer by one unit.
Intrinsic jitter	Jitter at the output of a device that is fed with a jitter free input signal.
Stuffing and wait time jitter	Non synchronous digital signals must be matched during multiplexing to the higher bit rate system by the insertion of stuffing bits. These stuffing bits must be removed when the signal is demultiplexed. The gaps which thus occur are equalized out by means of a smoothed clock signal. This smoothing is, however, imperfect, so stuffing and wait time jitter occurs.
Pattern jitter	Distortion in the digital signal leads to so-called inter-symbol interference, or time-domain impulse crosstalk. This results in interference between consecutive pulses in a digital signal which leads to jitter that is pattern-dependent.
Wander	Wander is a slow drift in the significant instants of a digital signal from their ideal equidistant positions in time. These delay variations occur, for example, in optical fibers as a result of diurnal temperature variations.

*Table 3: Causes of jitter*

Other causes of jitter are interference signals and phase noise. Jitter caused by interference signals is also called non-systematic jitter. Phase noise occurs despite the use of a central clock as a result of thermal noise and drift in the oscillator used. Various measurement methods have been developed for the different causes of jitter.

Measurements:

- Maximum tolerable jitter (MTJ)

Every digital input interface must be able to tolerate a certain amount of jitter before bit errors or synchronization errors occur. The measurement is made by feeding the input of the device under test with a digital signal modulated with sinusoidal jitter from a jitter generator. A bit error tester monitors the output of the device for bit errors and alarms which will occur sooner or later as the jitter amplitude is increased.

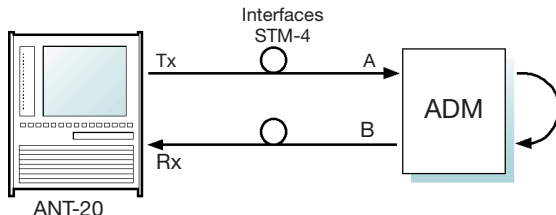

- Jitter transfer function (JTF)  
The jitter transfer function (JTF) of a network element indicates the degree to which jitter is passed on to the output.

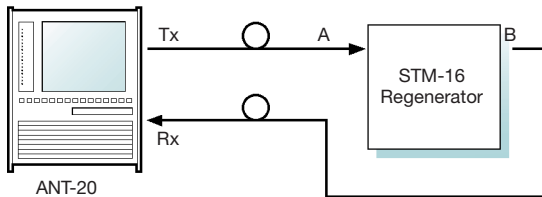

- Output jitter, intrinsic jitter  
Evaluation of broadband jitter using standardized combinations of high-pass and low-pass filters.
- Mapping jitter
- Pointer jitter  
Measurement of permitted pointer jitter is performed by feeding the synchronous demultiplexer with a SDH signal containing defined sequences of pointer activity.
- Combined jitter  
Jitter at PDH outputs caused by stuffing during mapping and by pointer activity.

- Wander analysis

An external, high-precision reference signal is required for performing wander measurements. The phase of the signal under test is compared with the reference signal phase. The very low frequency components require appropriately long measurement times (up to 12 days).

## Simulating pointer activity

If the jitter behavior of a tributary output in response to pointer activity is to be tested, so-called pointer sequences must be used. Such sequences have been defined by the ITU-T in order to guarantee network stability even under extreme conditions.

An example of such a sequence is termed 87-3 INC:

This is a sequence of steady pointer increments where 3 pointer actions are omitted after a sequence of 87 actions. This kind of sequence can occur as a result of loss of synchronization in a network element and can cause very large jitter amplitudes.

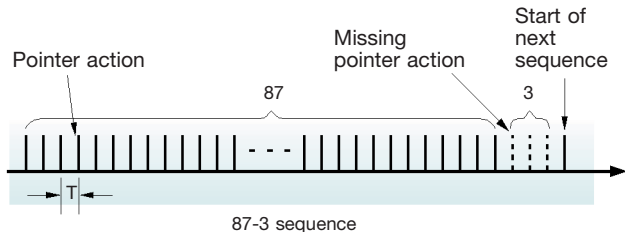



**Overview of current  
ITU-T Recommendations relevant to SDH**

- G.703: Physical/electrical characteristics of hierarchical digital interfaces
- G.707: Network node interface for the synchronous digital hierarchy (SDH)
- G.772: Protected monitoring points provided on digital transmission systems
- G.774: SDH information model for the network element view
- G.774.01: SDH performance monitoring for the network element view
- G.774.02: SDH configuration of the payload structure for the network element view
- G.774.03: SDH management of multiplex section protection for the network element view
- G.774.04: SDH management of sub network connection protection from the network element view
- G.774.05: SDH management of the connection supervision functionality (HCS/LCS) for the network element view
- G.780: Vocabulary of terms for SDH networks and equipment
- G.783: Characteristics of synchronous digital hierarchy (SDH) equipment functional blocks  
(replaces G.781, G.782 and G.783 version of 01/94)
- G.784: Synchronous digital hierarchy (SDH) management

- G.803: Architectures of transport networks based on the synchronous digital hierarchy (SDH)
- G.810: Definitions and terminology for synchronization networks
- G.811: Timing requirements at the output of primary reference clocks suitable for plesiochronous operation of international digital links
- G.813: Timing characteristics of SDH equipment slave clocks (SEC)
- G.825: The control of jitter and wander in digital networks based on the SDH
- G.826: Error performance parameters and objectives for international, constant bit rate digital paths at or above the primary rate
- G.831: Management capabilities of transport network based on the SDH
- G.832: Transport of SDH elements on PDH networks
- G.841: Types and characteristics of SDH network protection architectures
- G.842: Interworking of SDH network protection architectures
- G.957: Optical interfaces for equipments and systems relating to the SDH
- G.958: Digital line systems based on the SDH for use on optical fibre cables

- M.2101: Performance limit for bringing into service and maintenance of international SDH paths, and multiplex sections
- M.2110: Bringing into service international paths, sections and transmission systems
- M.2120: Digital path, section and transmission system fault detection and localization
- O.150: General requirements for instrumentation for performance measurements on digital transmission equipment
- O.17s: Jitter and wander measuring equipment for digital systems which are based on the SDH
- O.181: Equipment to assess error performance on STM-N SDH interfaces

## Abbreviations:

<b>A</b>	A1	RSOH frame synchronization byte; 1111 0110
	A2	RSOH frame synchronization byte; 0010 1000
	ADM	Add/drop multiplexer
	AIS	Alarm indication signal
	APS	Automatic protection switching (channels K1, K2)
	ATM	Asynchronous transfer mode
	AU	Administrative unit
	AU-n	Administrative unit, level n = 3, 4
AUG	Administrative unit group	
<b>B</b>	B1	BIP-8 parity word in regenerator section (RSOH)
	B2	BIP-N x 24 parity word in multiplex section (MSOH)
	B3	BIP-8 parity word in VC-3, 4 path (POH)
	BBE	Background block error (G.826)
	BBER	Background block error ratio (G.826)
	BER	Bit error ratio
	BIP-2	BIP-2 parity word in VC-1, 2 path (POH)
	BIP-N	Bit interleaved parity, N bits
BSHR	Bi-directional self-healing ring	
<b>C</b>	C-n	Container, n = 1 to 4
	C2	Signal label (VC-3, 4 POH)
	CAS	Channel-associated signaling
	CCM	Cross-connect multiplexing
	CMIP	Common management information protocol
	CSES	Consecutive severely errored seconds

<b>D</b>	D1–3	196 kbit/s DCC for regenerator section (RSOH)
	D4–12	576 kbit/s DCC for multiplex section (MSOH)
	DCC	Data communication channel
	DCN	Data communication network
	DWDM	Dense wavelength division multiplexing
	DXC	Digital cross-connect
<b>E</b>	E1	Electrical interface signal, 2048 kbit/s
	E2	Electrical interface signal, 8448 kbit/s
	E3	Electrical interface signal, 34368 kbit/s
	E4	Electrical interface signal, 139264 kbit/s
	E1	Service channel (voice) in regenerator section (RSOH)
	E2	Service channel (voice) in multiplex section (MSOH)
	EBC	Errored block count
	ECC	Embedded communication channel
	EDC	Error detection code
	EFS	Error-free second
	ES	Errored second (G.826)
	ESR	Errored seconds ratio (G.826)
<b>F</b>	F1	User channel, e.g. for operational service purposes (RSOH)
	F2	Path user channel for an end-to-end connection (POH)
	FAS	Frame alignment signal
<b>G</b>	G1	End-to-end path status (POH)

<b>H</b>	H1	Pointer byte 1: Bit nos. 1 to 4: New data flag; bit nos. 5, 6: (Unspecified), bit nos. 7, 8: Pointer value (highest 2 bits)
	H2	Pointer byte 2: Pointer value (lowest 8 bits)
	H3	Pointer byte 2: Negative justification opportunity
	H4	Payload indication (POH)
<b>I</b>	ISDN	Integrated services digital network
	ISO	International standardization organization
<b>J</b>	J0	Regenerator section trace (RSOH)
	J1	Path trace (POH in VC-3, 4)
	J2	Path trace (POH in VC-1, 2)
<b>K</b>	K1, K2	(MSOH) APS channels for APS signaling and back-up line switching
	K3, K4	(POH) APS channels for APS signaling and back-up line switching
<b>L</b>	LAN	Local area network
	LO	Lower order
	LOF	Loss of frame
	LOM	Loss of multiframe
	LOP	Loss of pointer
	LOS	Loss of signal

<b>M</b>	M1	MS-REI byte (MSOH)
	MI	Management information
	MO	Managed object
	MS	Multiplexer section
	MS-AIS	Multiplexer section AIS
	MSOH	Multiplexer section overhead
	MTIE	Maximum time interval error
<b>N</b>	N1, 2	Network operator bytes (POH)
	NDF	New data flag
	NE	Network element
<b>O</b>	OAM	Operation, administration and management
	OC-N	Optical carrier, N = 1; 4; 16
	OH	Overhead
	OOF	Out of frame
<b>P</b>	PDH	Plesiochronous digital hierarchy
	PLL	Phase-locked loop
	POH	Path overhead
	PRBS	Pseudo-random binary sequence
	PRC	Primary reference clock
<b>Q</b>	QoS	Quality of service

<b>R</b>	RDI	Remote defect indicator
	REI	Remote error indicator
	ROSE	Remote operations service element
	RSOH	Regenerator section overhead
<b>S</b>	S1	Synchronization status byte (MSOH)
	SDH	Synchronous digital hierarchy
	SEC	SDH equipment clock
	SES	Severely errored second
	SESR	Severely errored seconds ratio
	SHR	Self-healing ring
	SMN	SDH management network
	SMS	SDH management sub-network
	SOH	Section overhead
	SPRING	Shared protection ring
	STM	Synchronous transport module
	STM-N	Synchronous transport module, level N = 1, 4, 16, 64
STS	Synchronous transport signal	
<b>T</b>	TMN	Telecommunications management network
	TU	Tributary unit
	TU-m	Tributary unit, level m = 1...3
	TUG-m	Tributary unit group, level m = 1, 2
<b>U</b>	UAS	Unavailable second
	UAT	Unavailable time



	UNEQ	Unequipped
	UI	Unit interval
<b>V</b>	V5	POH byte (VC-1, 2)
	VC	Virtual container
	VC-n	Virtual container, level n = 1, 2, 3, 4
	VC-n-Xc	Concatenated virtual container, level n, X concatenated VCs
	VP	Virtual path
<b>W</b>	WDM	Wavelength division multiplexing

# **Pocket Guide SONET**

Fundamentals  
and SONET Testing

# **Pocket Guide GSM**

Fundamentals in  
Mobile Radio Networks

E 5.98/WG1/1006 GN v. 956/5.0

